

COMPACT VENTIL

INSTALLATION

dimensions in mm

types 215, 22, 33

type 11

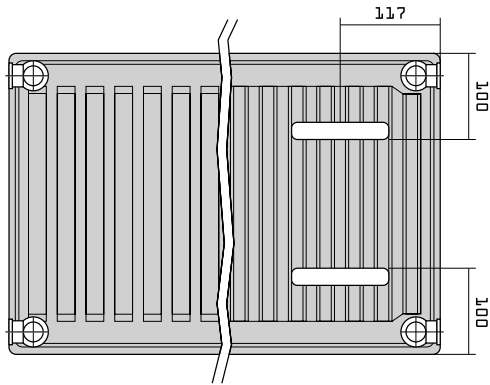

Standard brackets



(type 11)

Invisible bracket (Monclac)

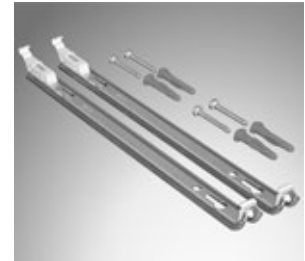

(types 215, 22, 33)

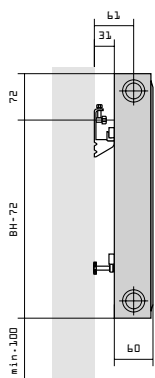

type 11

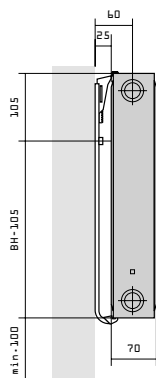

type 215

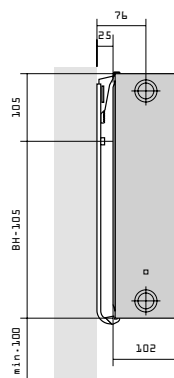

type 22

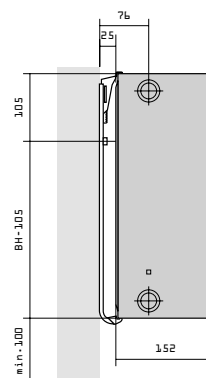

type 33 (right)

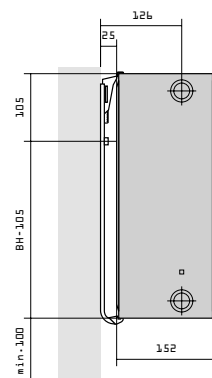

type 33 (left)

water content : l/m

type	300	400	450	500	600	900
11	1.50	2.20	2.30	2.90	3.40	4.50
215			4.80	5.20	6.10	8.80
22	3.20	4.20	4.80	5.20	6.10	8.80
33	5.10	6.30	7.00	7.50	8.80	13.00

weight : kg/m

type	300	400	450	500	600	900
11	9.00	12.60	14.40	16.10	19.50	29.00
215			21.80	23.70	28.40	42.30
22	16.40	21.60	24.30	27.00	32.70	51.40
33	24.20	33.20	37.40	42.20	51.10	77.40